

# High Static Pressure Duct

**NEW Model :** ARYC72LHTA [3phase], ARYC90LHTA [3phase]



ARYC72LHTA



ARYC90LHTA



Wired R.C.



## Features

### High energy efficiency

Significantly greater efficiency is realized by using DC twin rotary compressor, all DC inverter technology, and large heat exchanger.

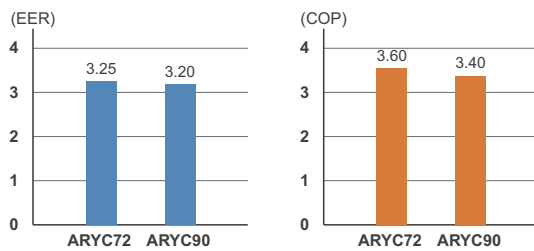

### 5 Static Pressure selection

Improvement and design flexibility has allowed multiple fan speeds and static pressure modes. Low noise is realized by adopting plastic case, plastic fan.

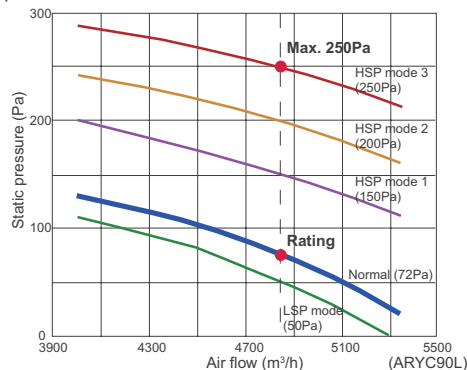

### Outdoor unit quiet operation

A low outdoor noise operation mode allows the outdoor unit to have two quiet mode operation settings.

### Peak cut operation

A peak power consumption mode controls a 4 step outdoor operation control to cut down energy usage at peak energy usage times.

### Easy Service & Maintenance

- Split front panel allows for maintenance from top or bottom of the outdoor unit
- Fan motors of the indoor unit can be removed separately

Outdoor unit

Indoor unit

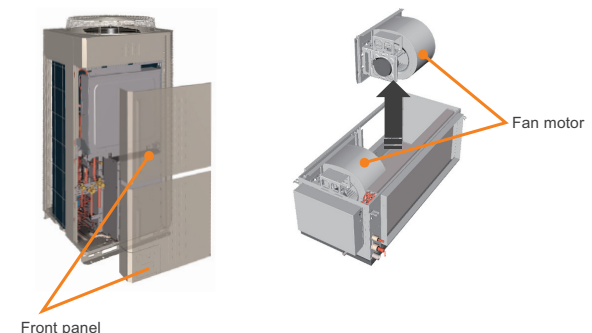

### Pursuance of amenity performance

Various remote controllers and sensors can be selected



### Optional parts

- Wired Remote Controller: UTY-RNNYM, UTY-RVNYM
- Simple Remote Controller: UTY-RSNYM
- Remote Sensor Unit: UTY-XSZX
- External Control Set: UTD-ECS5A
- External Connect Kit: UTY-XWZXZ2, UTY-XWZXZ4

